

PCI-2TE series

1 – 15 μm HgCdTe two-stage thermoelectrically cooled, optically immersed photoconductive detectors

PCI-2TE series features two-stage thermoelectrically cooled IR photoconductive detectors based on sophisticated HgCdTe heterostructures for the best performance and stability, optically immersed in order to improve parameters of the devices. The detectors are optimized for the maximum performance at λ_{opt} . Cut-on wavelength is limited by GaAs transmittance ($\sim 0.9 \mu\text{m}$). The devices should operate in optimum bias voltage and current readout mode. Performance at low frequencies is reduced due to 1/f noise. The 1/f noise corner frequency increases with the cut-off wavelength. 3° wedged sapphire (wAl₂O₃) or zinc selenide anti-reflection coated (wZnSeAR) window prevents unwanted interference effects.

Spectral response ($T_a = 20^\circ\text{C}$)

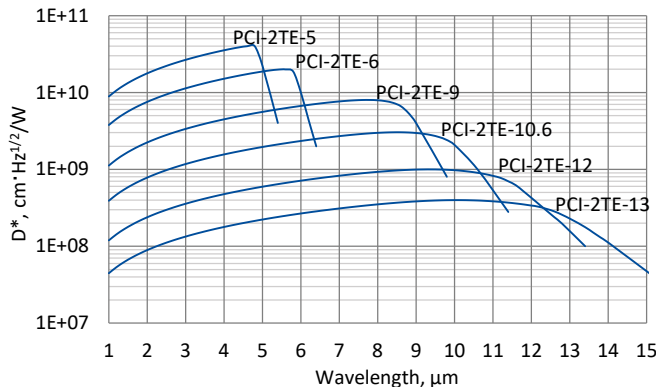

Exemplary spectral detectivity, the spectral response of delivered devices may differ.

Specification ($T_a = 20^\circ\text{C}$)

Parameter	Detector type					
	PCI-2TE-5	PCI-2TE-6	PCI-2TE-9	PCI-2TE-10.6	PCI-2TE-12	PCI-2TE-13
Active element material	epitaxial HgCdTe heterostructure					
Optimum wavelength λ_{opt} , μm	5.0	6.0	9.0	10.6	12.0	13.0
Detectivity $D^*(\lambda_{peak}, 20\text{kHz})$, $\text{cm}^2\cdot\text{Hz}^{1/2}/\text{W}$	$\geq 4.0 \times 10^{10}$	$\geq 2.0 \times 10^{10}$	$\geq 8.0 \times 10^9$	$\geq 2.8 \times 10^9$	$\geq 1.0 \times 10^9$	$\geq 4.0 \times 10^8$
Detectivity $D^*(\lambda_{opt}, 20\text{kHz})$, $\text{cm}^2\cdot\text{Hz}^{1/2}/\text{W}$	$\geq 2.0 \times 10^{10}$	$\geq 1.0 \times 10^{10}$	$\geq 4.0 \times 10^9$	$\geq 1.0 \times 10^9$	$\geq 4.5 \times 10^8$	$\geq 2.3 \times 10^8$
Current responsivity-optical area length product $R_i(\lambda_{opt}) \cdot L_o$, A·mm/W	≥ 3.0	≥ 1.5	≥ 0.225	≥ 0.1	≥ 0.05	≥ 0.03
Time constant τ , ns	≤ 20000	≤ 4000	≤ 40	≤ 10	≤ 3	≤ 2
1/f noise corner frequency f_c , Hz	$\leq 10\text{k}$				$\leq 20\text{k}$	
Bias voltage-optical area length ratio V_b/L_o , V/mm	≤ 0.2	≤ 0.32	≤ 0.2	≤ 0.225	≤ 0.15	≤ 0.18
Resistance R , Ω	≤ 1200	≤ 800	≤ 400	≤ 300	≤ 200	≤ 150
Active element temperature T_{det} , K	~ 230					
Optical area A_o , mm×mm	0.5×0.5, 1×1, 2×2					
Package	TO8, TO66					
Acceptance angle Φ	$\sim 36^\circ$					
Window	wAl ₂ O ₃		wZnSeAR			

Two-stage thermoelectric cooler parameters

Parameter	Value
T_{det} , K	~ 230
V_{max} , V	1.3
I_{max} , A	1.2
Q_{max} , W	0.36

Thermistor characteristics

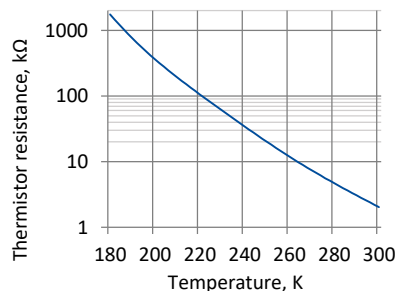

Spectral transmission of wAl₂O₃ and wZnSeAR windows (typical example)

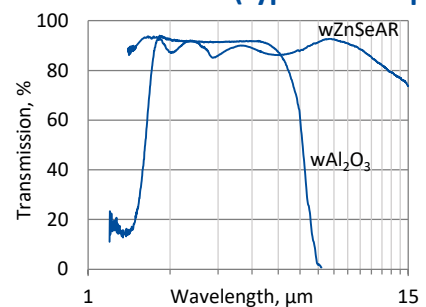

Mechanical layout, mm

2TE-T08 package

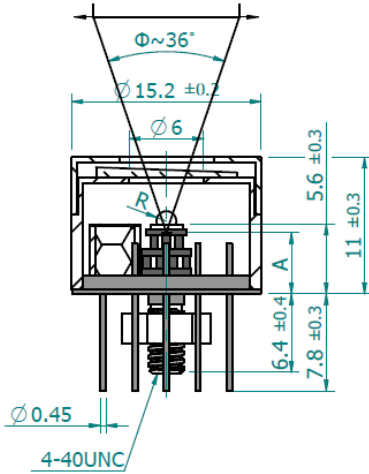

Parameter	Value		
Immersion microlens shape	hyperhemisphere		
Optical area A_0 , mm×mm	0.5×0.5	1×1	2×2
R, mm	0.5	0.8	1.25
A, mm	4.1±0.3	3.2±0.3	1.85±0.30

Φ – acceptance angle
 R – hyperhemisphere microlens radius
 A – distance from the bottom of 2TE-T08 header to the focal plane

Bottom view

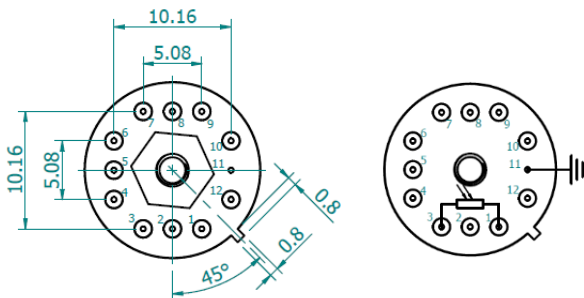

Function	Pin number
Detector	1, 3
Thermistor	7, 9
TE cooler supply	2(+), 8(-)
Chassis ground	11
Not used	4, 5, 6, 10, 12

2TE-T066 package

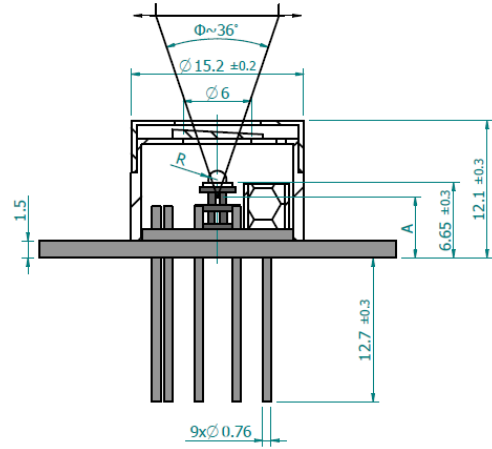

Parameter	Value		
Immersion microlens shape	hyperhemisphere		
Optical area A_0 , mm×mm	0.5×0.5	1×1	2×2
R, mm	0.5	0.8	1.25
A, mm	5.15±0.30	3.2±0.3	1.85±0.30

Φ – acceptance angle
 R – hyperhemisphere microlens radius
 A – distance from the bottom of 2TE-T066 header to the focal plane

Top view

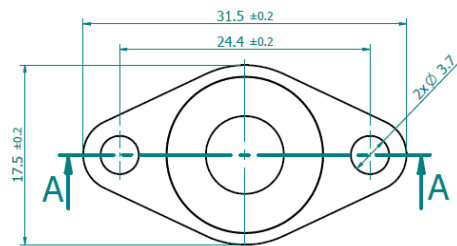

Bottom view

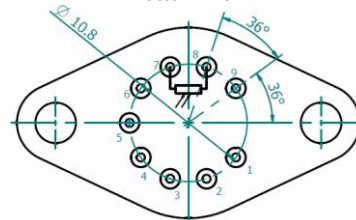

Function	Pin number
Detector	7, 8
Thermistor	5, 6
TE cooler supply	1(+), 9(-)
Not used	2, 3, 4

Dedicated preamplifiers



„all-in-one“ AIP



programmable PIP



standard MIP



small SIP-T08